

# IRIDE.

dental furniture designed and made in **Italy.**





La nostra storia ..... pg | 5-6  
*Notre histoire*

Perchè scegliere Iride?..... pg | 7-10  
*Pourquoi choisir Iride?*

Laboratorio  
*Laboratoire*

Linea classica  
*Gamme classique*

serie EKO..... pg | 11-16

serie TEC..... pg | 17-20

serie 2000..... pg | 21-26

serie SKY..... pg | 27-30

serie MELISSA..... pg | 31-34

serie ELITE..... pg | 35-38

Linea contemporanea  
*Gamme contemporaine*

serie SESTO ELEMENTO..... pg | 39-44

serie CHIMERA..... pg | 45-48

Cad cam..... pg | 49-52  
*CFAO*

Sala gessi..... pg | 53-58  
*Salle de plâtre*

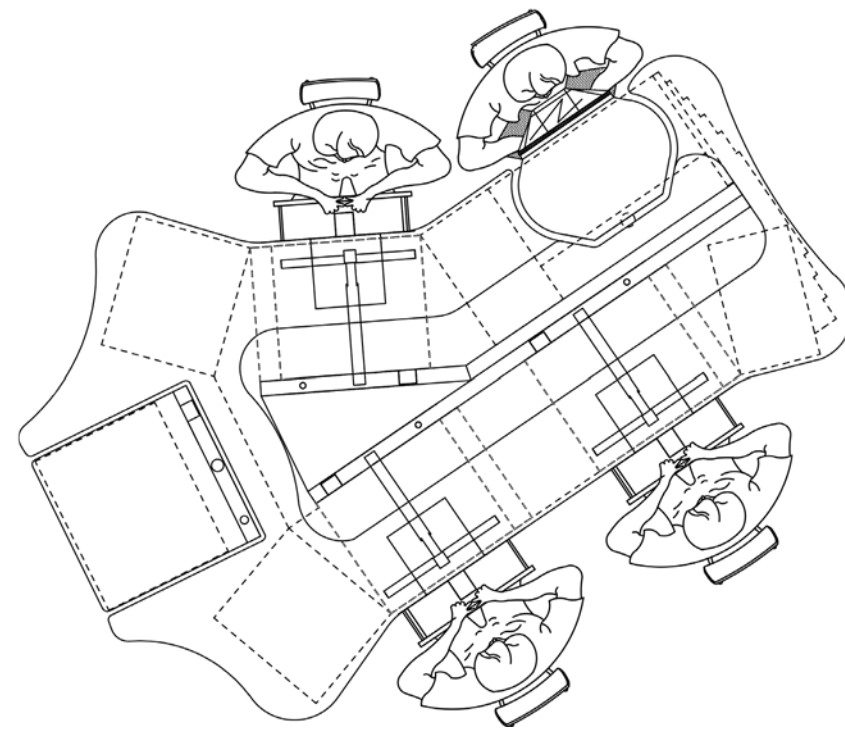

## Accessori

Accessoires

BOX.....pg | 59-60  
Box

MINIBOX.....pg | 61-62  
Minibox

CAPPETTA.....pg | 63-64  
Box de polissage

CAPPA.....pg | 65-66  
Hottes

ASPIRAZIONI.....pg | 67-68  
Aspirations

RASTRELLIERA.....pg | 69-70  
Rail porte boite

SEDIE E ACCESSORI POSTO LAVORO.....pg | 71-72  
Chaises et accessoires place travail

CUPOLA.....pg | 73-74  
Coupoles

LAMPADE.....pg | 75-78  
Lampes

Personalizzazioni.....pg | 79-80  
Personnalisations

Moduli.....pg | 81-98  
Éléments modulaire



# La nostra storia

## L'histoire d'Iride International

# IRIDE

Dal 1986 IRIDE international progetta e realizza arredamento e accessori, per studi odontoiatrici e laboratori odontotecnici.

Depuis 1986, IRIDE international conçoit et fabrique des meubles et accessoires pour cabinets dentaires et laboratoires dentaires.



Le sue radici però, sono ben più profonde, infatti il suo fondatore e ideatore entrò già negli anni '70 nell'imprenditoria del settore dentale e, con la sua genialità ed inventiva brevettuale, il Sig. Enzo Tonin fondò "IRIDE".

Cependant, ses racines sont beaucoup plus profondes, en fait son fondateur et créateur est déjà entré dans l'industrie dentaire dans les années 1970 et avec son génie et son inventivité brevetée, M. Enzo Tonin a fondé "IRIDE".

IRIDE développe des lignes innovantes d'étude et de laboratoire. De nombreuses séries voient le jour qui améliorent et soutiennent la méthode de travail des professionnels du secteur, garantissant la plus haute qualité des produits.

IRIDE sviluppa linee innovative per studio e laboratorio. Nascono molte serie che migliorano e assecondano il metodo di lavoro dei professionisti del settore garantendo un altissima qualità nei prodotti.

1970

1986



Enzo Tonin fonda "IRIDE"

Enzo Tonin fonde "IRIDE"

1999



Les produits IRIDE sont continuellement améliorés, intégrant de nouvelles technologies et détails techniques qui garantissent une longue durée de vie, une hygiène maximale et une facilité de nettoyage. Au cours de ces années, Line est née, une série qui englobe tous ces concepts et valeurs d'une famille qui ne fait aucun compromis.

I prodotti IRIDE vengono continuamente migliorati, integrando nuove tecnologie e dettagli tecnici che garantiscono una lunga durata, massima igiene e facilità di pulizia. In questi anni nasce Line, una serie che racchiude tutti questi concetti e i valori di una famiglia che non scende a compromessi.



2005



IRIDE sviluppa la serie Quadra dal design essenziale e pulito. Ogni dettaglio è sviluppato per garantire funzionalità, facilità di pulizia ed evitare che si formino depositi batterici. Quadra inoltre garantisce un'eccezionale versatilità e possibilità di personalizzazione da parte del cliente.

IRIDE développe la série Quadra avec un design essentiel et épuré. Chaque détail est développé pour assurer la fonctionnalité, la facilité de nettoyage et empêcher la formation de dépôts bactériens. Quadra garantit également une polyvalence exceptionnelle et la possibilité de personnalisation par le client.

Après sa mort subite et prématurée en 2006, ses héritiers et tout le personnel de l'IRIDE, forts de leurs racines et motivés par ce qui était si unique que M. Enzo continue de grandir et de faire grandir IRIDE selon les valeurs et les traditions du passé et d'un homme qui savait voir au-delà ...

Dopo la sua prematura e improvvisa scomparsa nell'anno 2006, i suoi eredi e tutto lo staff IRIDE, forti delle sue radici e motivati da quanto di così unico aveva creato il sig. Enzo continuano tutt'ora a crescere e a far crescere IRIDE secondo valori e tradizioni di un tempo e di un uomo che sapeva vedere oltre...

illuminazione a led-rgb

éclairage led-rgb



2014

L'innovazione continua...

L'innovation continue...

Nasce EX-L, una linea innovativa che integra design e facilità d'utilizzo. La forma dei frontali infatti permette l'apertura dei cassetti senza l'aggiunta di maniglie o sistemi elettromeccanici. La forma diventa funzione. EX-L est né, une ligne innovante qui intègre design et facilité d'utilisation. En effet, la forme des façades permet d'ouvrir les tiroirs sans ajout de poignées ou de systèmes électromécaniques. La forme devient fonction.

FLY est né, la dernière évolution de l'éclairage LED pour les établis de laboratoire. Entièrement en aluminium, un design innovant avec une attention à chaque détail. FLY se moule selon les besoins de l'utilisateur, offrant des ajustements infinis de mouvement et d'intensité de la lumière. Une nouvelle référence pour le secteur dentaire.

Nasce FLY, l'ultima evoluzione dell'illuminazione a LED per i banchi da laboratorio. Completamente in alluminio, un design innovativo curato in ogni dettaglio. FLY si plasma a seconda delle esigenze dell'utente offrendo infinite regolazioni di movimento e d'intensità di luce. Un nuovo riferimento per il settore dentale.

2017

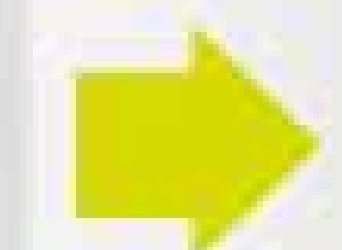

IRIDE continua a crescere e sviluppare soluzioni all'avanguardia. Porta avanti forti legami con il territorio, garantendo un prodotto realizzato da maestranze italiane, per offrire ai nostri clienti la qualità di un prodotto 100% made in Italy. IRIDE continue de croître et de développer des solutions de pointe. Elle entretient des liens forts avec le territoire, garantissant un produit fabriqué par des travailleurs italiens, pour offrir à nos clients la qualité d'un produit 100% made in Italy.

# Perchè scegliere Iride?

Pourquoi choisir Iride?

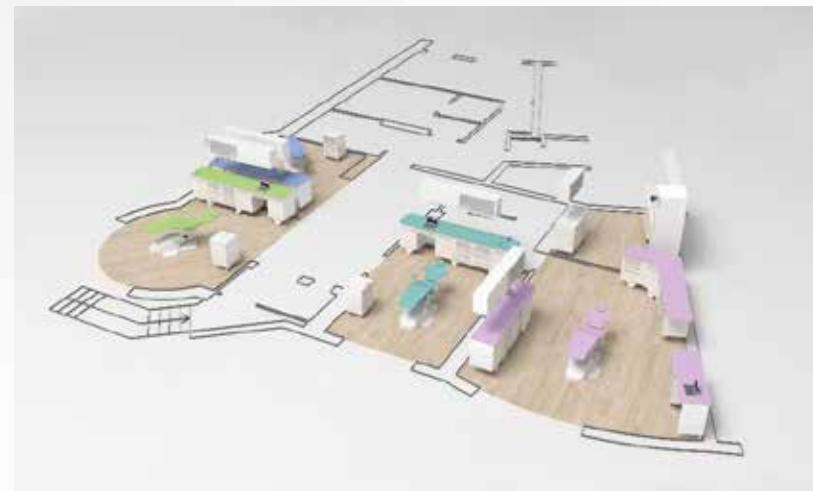

## Sviluppiamo il tuo progetto

I progettisti IRIDE analizzeranno le tue esigenze e ti affiancheranno durante tutte le fasi di sviluppo del progetto. Dallo schizzo di studio iniziale al disegno delle piante, un team composto da architetti e designer ti aiuterà nello sviluppo dei singoli componenti fino alla definizione di ambienti completi. Verificheremo insieme a te ogni dettaglio, materiale, colore e potrai visualizzare l'anteprima fotorealistica del tuo progetto.

## Nous développons votre projet

*Les designers Iride analysent vos besoins et vous accompagnent dans les phases de développement du projet. Du croquis d'étude initiale à la conception des pièces, une équipe d'architectes et de designers vous accompagne dans l'élaboration des composants individuels jusqu'à la définition d'environnements complets. Nous vérifierons avec vous chaque détail, matériau, couleur, et vous pourrez visualiser l'aperçu photoréaliste de votre projet.*

## Realizziamo i nostri prodotti a partire dalla materia prima

Scegliamo accuratamente i fornitori di materie prime e le controlliamo attentamente prima che entrino nel ciclo produttivo. Utilizziamo lamiere elettrozincate e la tecnica della rivettatura per mantenerne le proprietà. I nostri tecnici specializzati, partendo dalla materia prima, realizzano le scocche e i componenti dei mobili garantendo un'altissima qualità dei semilavorati e la possibilità di realizzare componenti ed ambienti su misura delle tue esigenze. Riusciamo così a controllare ogni fase della realizzazione ed assicurare ai nostri clienti un prodotto che dura nel tempo.

## Nous fabriquons nos produits à partir de la matière première

*Nous choisissons soigneusement les fournisseurs de matières premières et les contrôlons soigneusement avant qu'ils n'entrent dans le cycle de production. Nous utilisons des tôles électro-galvanisées et la technique de rivetage pour conserver leurs propriétés. Nos techniciens spécialisés, à partir de la matière première, créent les coques et les éléments de mobilier garantissant la plus haute qualité des produits semi-finis et la possibilité de créer des composants et des environnements adaptés à vos besoins. De cette façon, nous sommes en mesure de contrôler chaque phase de la réalisation et d'assurer à nos clients un produit qui dure dans le temps.*

# Perchè scegliere Iride?

## Pourquoi choisir Iride?



### Qualità 100 % made in Italy

IRIDE porta avanti forti legami con il territorio. Garantiamo un prodotto realizzato da maestranze italiane, per offrirti una qualità 100% made in Italy. A partire dal design, studiato dai nostri progettisti per ridurre l'insorgere dei batteri, facilitare la pulizia e durare nel tempo, ogni fase di lavorazione viene eseguita all'interno dell'azienda: dalla creazione dei componenti, alla verniciatura fino al pre-montaggio del progetto. In questo modo riusciamo a controllare ogni dettaglio del prodotto e realizzare progetti su misura delle tue necessità.

### Qualité 100% made in Italy

IRIDE INTERNATIONAL entretient des liens forts avec le territoire. Nous garantissons un produit fabriqué par des travailleurs italiens, pour vous offrir une qualité 100% made in Italy. Partant de la conception, étudiée par nos designers pour réduire l'apparition de bactéries, faciliter le nettoyage et durer dans le temps, chaque étape de transformation est réalisée au sein de l'entreprise: de la création des composants, à la peinture jusqu'au pré-assemblage. du projet. De cette façon, nous sommes en mesure de contrôler chaque détail du produit et de créer des projets adaptés à vos besoins.

### Collaudiamo il tuo prodotto prima della consegna

I prodotti IRIDE sono concepiti dai nostri progettisti e realizzati in azienda per durare nel tempo, garantire massimi livelli d'igiene e facilità di pulizia. I tecnici IRIDE infatti realizzano un primo montaggio dei mobili all'interno dello stabilimento, verificano l'idoneità dei componenti, collaudano il corretto funzionamento e approvano il prodotto. In questo modo garantiamo l'alta qualità dei nostri mobili, che nascono e vengono realizzati interamente all'interno dell'azienda.

### Nous testons votre produit avant la livraison

Les produits IRIDE INTERNATIONAL sont conçus par nos designers et fabriqués en interne pour durer dans le temps, garantir les plus hauts niveaux d'hygiène et une facilité de nettoyage. En effet, les techniciens d'IRIDE INTERNATIONAL réalisent un premier montage du mobilier à l'intérieur de l'usine, vérifient l'adéquation des composants, testent leur bon fonctionnement et approuvent le produit. De cette façon, nous garantissons la haute qualité de nos meubles, qui sont nés et fabriqués entièrement au sein de l'entreprise.

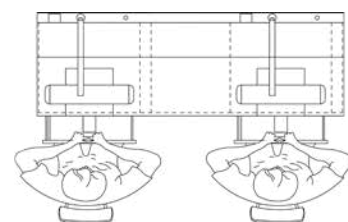

L 1940mm  
P 652mm  
H 900mm

## Eko La risposta ad ogni esigenza Eko La réponse à chaque besoin

Eko è la nostra serie tradizionale, adatta a chi ricerca l'essenziale, senza rinunciare alla funzionalità  
*Eko est notre série des établis traditionnelle, adaptée à ceux qui recherchent l'essentiel, sans sacrifier la fonctionnalité*

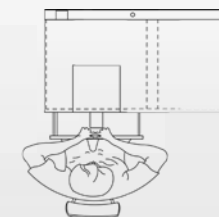

L 1230mm  
P 652mm  
H 900mm

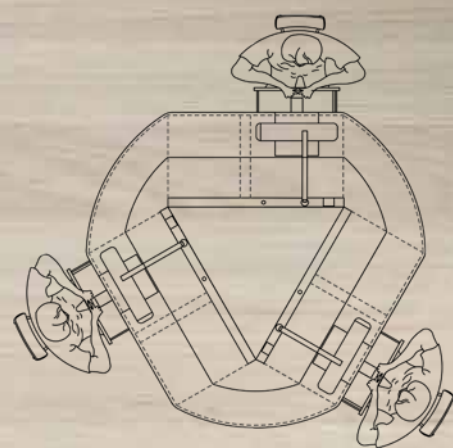

L 2340mm  
P 2170mm  
H 900mm



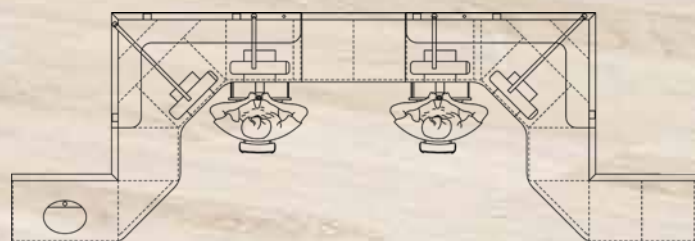

L 6480mm  
P 2170mm  
H 900mm

# Tec Più comodità ed efficienza nel lavoro di ogni giorno

*Tec Plus de confort et d'efficacité dans le travail quotidien*

Tec incorpora la tradizione della serie Eko e la novità d'essere posta su telaio  
*Tec intègre la tradition de la série Eko et la nouveauté d'être placé sur des petits pieds.*

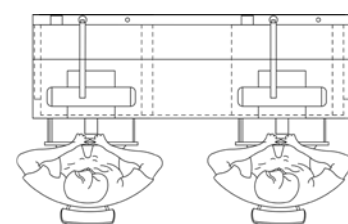

L 2020mm  
P 652mm  
H 950mm

pg | 17-18

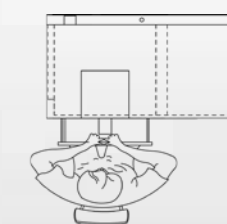

L 1270mm  
P 652mm  
H 950mm

linea classica

Tec

IRIDE.

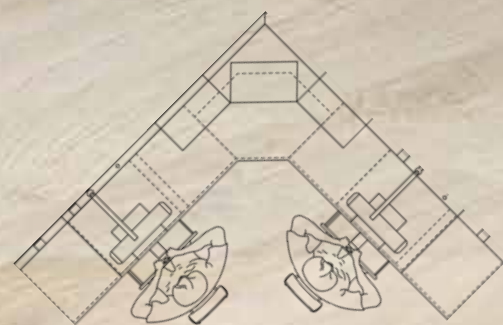

L 2640mm  
P 2640mm  
H 950mm

## 2000 Design che sfida il tempo

*2000 Un design qui défie le temps*

2000 è la nostra serie morbida: i cassetti arrotondati promettono un comfort assoluto

*2000 est notre série sinieuse : les tiroirs arrondis promettent un confort absolu*

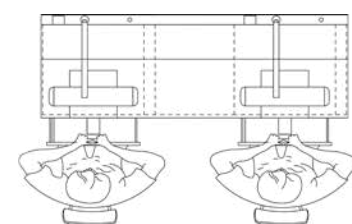

L 1980mm  
P 652mm  
H 900mm

pg | 21-22

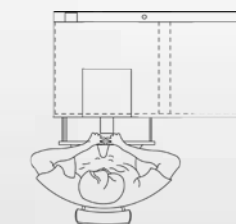

L 1250mm  
P 652mm  
H 900mm

linea classica

2000

IRIDE.

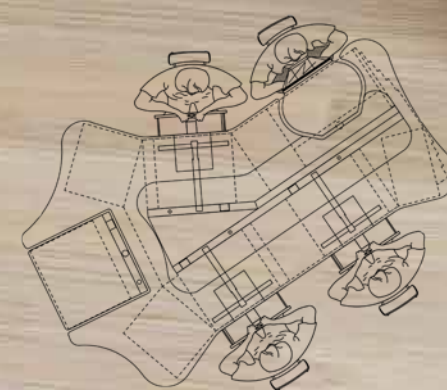

L 3350mm  
P 2300mm  
H 900mm

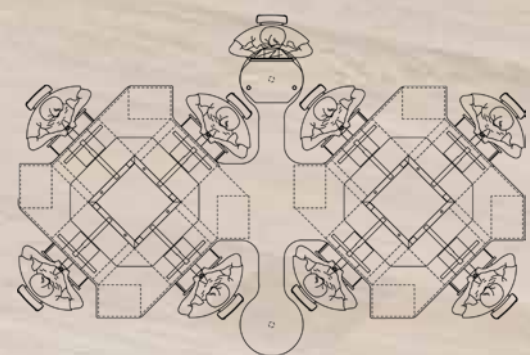

L 5620mm  
P 3420mm  
H 900mm

**Sky** Funzionalità inarrivabile  
*Sky Fonctionnalité inégalée*

Sky incorpora la tradizione della serie 2000 e la novità d'essere posta su telaio  
*Sky intègre la tradition de la série 2000 et la nouveauté d'être placé sur des petits pieds*

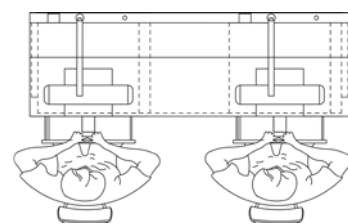

L 2060mm  
 P 652mm  
 H 950mm

pg | 27-28

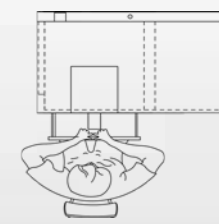

L 1290mm  
 P 652mm  
 H 950mm

linea classica

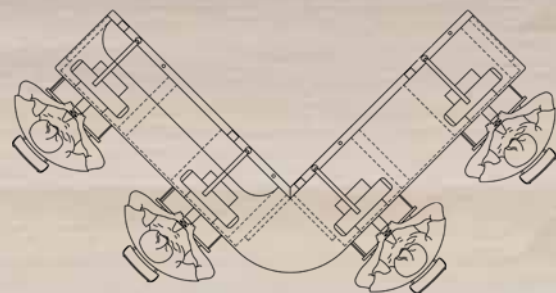

L 3730mm  
P 2120mm  
H 950mm



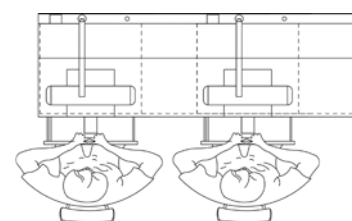

L 2000mm  
P 652mm  
H 900mm

**Melissa**

pg | 31-32

## Melissa Adatta alle tue esigenze *Melissa Adapté à vos besoins*

Melissa racchiude in sé tutta l'accessorialità e comodità di cui hai bisogno

*Melissa contient tous les accessoires et le confort dont vous avez besoin*

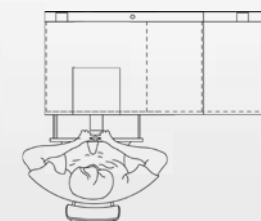

L 1010mm  
P 652mm  
H 900mm

L 1510mm  
P 652mm  
H 900mm

linea classica

**IRIDE.**

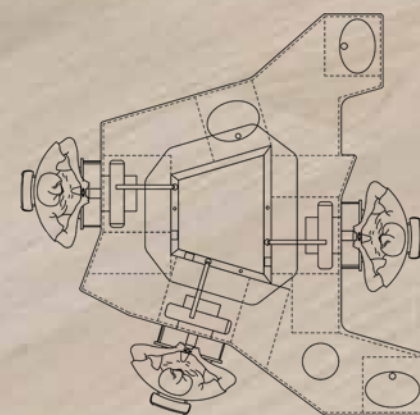

L 2900mm  
P 3370mm  
H 900mm

**Elite** La completezza  
*Elite L'exhaustivité*

Elite è, da sempre, la nostra pupilla. Qui, design, comfort e accessorietà si fondono insieme nella tua area di lavoro  
*Elite a toujours été notre phare. Ici, design, confort et accessoires se conjuguent dans votre espace de travail*

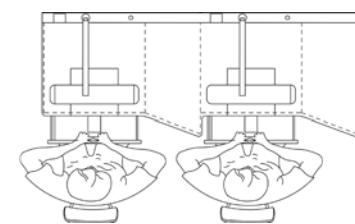

L 2000mm  
P 652mm  
H 900mm

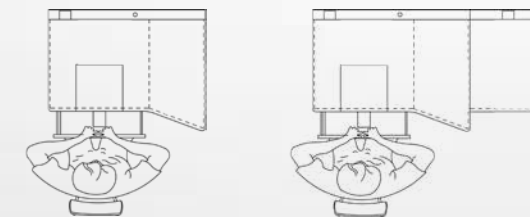

L 1010mm  
P 652mm  
H 900mm

L 1510mm  
P 652mm  
H 900mm



L 3800mm  
P 1480mm  
H 900mm

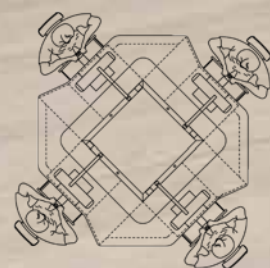
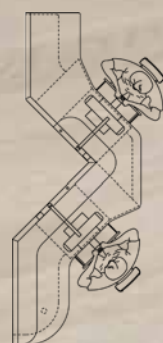

L 2430mm  
P 2430mm  
H 900mm

## Sesto elemento L'evoluzione

### *Sesto elemento L'Évolution*

Il Sesto elemento è la fusione di forma e passione. È l'evoluzione di un mobile che, con le sue linee eleganti ed innovative, racchiude il cuore pulsante del banco

*Sesto elemento est la fusion de la forme et de la passion. C'est l'évolution d'un meuble qui, avec ses lignes élégantes et innovantes, il enserre le cœur battant de l'établi*



L 1950mm  
P 650mm  
H 950mm

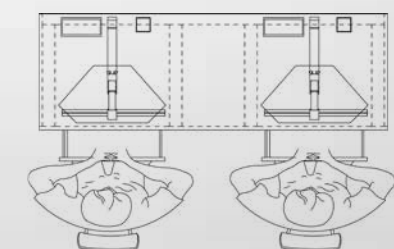



Abbiamo il piacere di presentarvi l'apparizione del SESTO ELEMENTO, una delle nostre più soddisfacenti creazioni, nel video "Dorado", brano di successo dei rapper Mahmood, Sfera Ebbasta e Feid. Se non l'avete ancora fatto, vi invitiamo ad andare a guardarlo su YouTube!

*Nous sommes heureux de vous présenter l'apparition de notre « Sesto Elemento », l'une de nos créations les plus satisfaisantes, dans la vidéo "Dorado", une chanson à succès des rappeurs Mahmood, Sfera Ebbasta et Feid. Si vous ne l'avez pas encore fait, nous vous invitons à aller le regarder sur YouTube!*



# Chimera II progresso

## Chimera Le progrès

Chimera è fusione. Fusione di forme, linee, funzionalità e dinamicità di tutte le nostre serie: partendo dalla classicità della linea Line, al rigore del Sesto elemento. Attraverso il progresso di tutte le nostre creazioni, abbiamo ottenuto il risultato finale, che, dietro ad un'inconfondibile eleganza, nasconde la sua estrema pulizia e semplicità

*Chimera est fusion. Fusion des formes, des lignes, de la fonctionnalité et du dynamisme de tous les nôtres série: du classicisme de la ligne Line, à la rigueur de Sesto Elemento. Par le progrès de toutes nos créations, nous avons obtenu le résultat final, qu'en plus d'une élégance incomparable, dissimule son extrême propreté et simplicité*

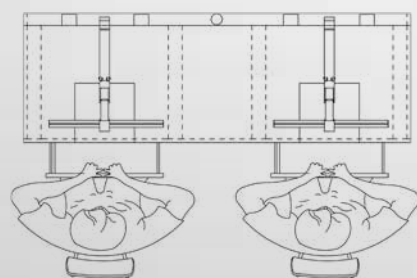

L 2000mm  
P 660mm  
H 960mm





# Cad-Cam II design che segue l'innovazione

*CFAO Un design qui suit l'innovation*

Le nostre postazioni Cad-Cam sono progettate e costruite attorno alle tue esigenze, per garantirti il massimo comfort. Sono, quindi, componibili e personalizzabili nelle soluzioni

*Nos places de travail CFAO sont conçus et construits autour de vos besoins, pour vous garantir un confort maximal. Ils sont donc modulables et personnalisables dans leurs solutions*

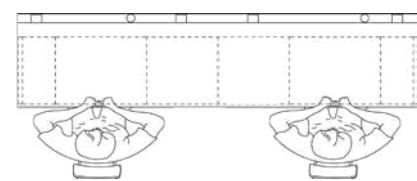

Cad-Cam

L 2820mm  
P 652mm  
H 832mm

pg | 49-50

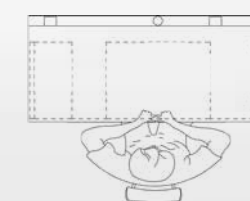
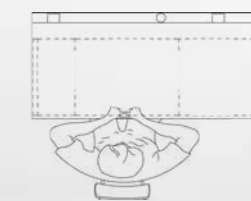

linea classica

L 1420mm  
P 652mm  
H 832mm

L 1420mm  
P 652mm  
H 832mm

IRIDE.

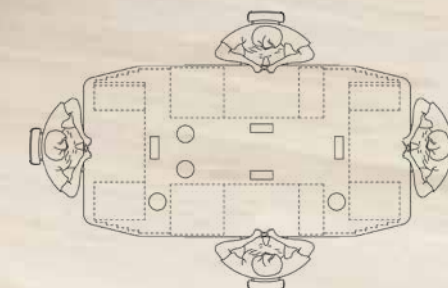

L 3050mm  
P 1600mm  
H 900mm

# Sala gessi su misura di ogni spazio

## Salle de plâtre Sur mesure pour tout espace

La versatilità senza confini delle nostre sale gessi, ti permette di spaziare con la creatività. Non importa di quale spazio disponi, i progettisti Iride ti aiuteranno a configurare una sala gessi su misura delle tue esigenze

*La polyvalence sans frontières de nos salles de plâtre vous permet d'espacez avec créativité. Quel que soit l'espace dont vous disposez, les designers Iride vous aideront à configurer une salle de plâtre adaptée à vos besoins*





Sala gessi

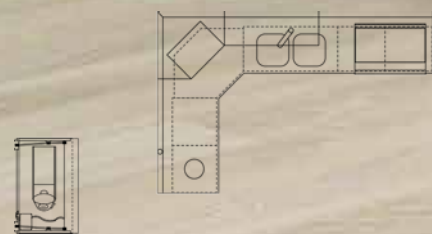

LATO CORTO 1925mm  
LATO LUNGO 2925mm  
P 652mm  
H 950mm

pg | 55-56

linea classica



CAPPA  
L 1200mm  
P 800mm  
H 2110mm

CAPPETTA  
L 750mm  
P 520mm  
H 585mm

IRIDE.

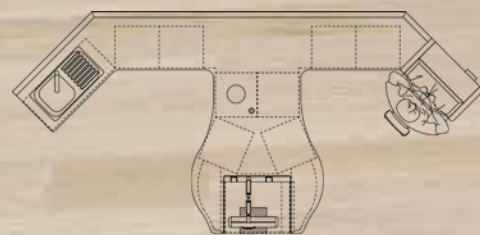

L 5350mm  
P 2500mm  
H 1000mm

## BOX Finitura sottovetro

### Box Finition sous verre

Con il nostro Box, sicurezza e salute sono garantite: grazie al sistema sottovetro, tutti i componenti nocivi liberati dalle lavorazioni vengono convogliati da un motore ad induzione, e raccolti in un apposito filtro intercambiabile

*Avec notre Box, la sécurité et la santé sont garanties : grâce au système sous verre, tous les composants nocifs libérés par le traitement sont véhiculés par un moteur à induction et collectés dans un filtre spécial interchangeable.*

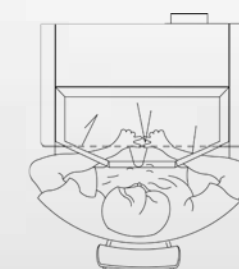

L 840mm  
H 1330mm  
P 670mm

## Minibox Ritocchi finali

### *Minibox Retouche finale*

Più compatto rispetto al Box, il Minibox è un accessorio indispensabile per chi ricerca la perfezione: è uno strumento versatile e utile per i ritocchi finali

*Plus compacte que le Box, le Minibox est un accessoire indispensable pour ceux qui recherchent la perfection : c'est un outil polyvalent et utile pour les retouches finales*



TAVOLINO FISSO  
L 730  
P 650mm  
H 840

Minibox

pg | 61-62

linea classica

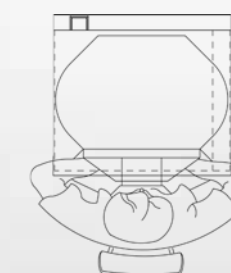

MINIBOX  
L 710mm  
P 620mm  
H 550mm

IRIDE.





TAVOLO SALISCENDI  
L 750mm  
P 652mm  
H 850mm/1150mm

## Cappetta Aspirante per pulitrice *Box de polissage*

Accessorio indispensabile per eseguire lavori di lucidatura; disponibile sia nella versione classica, sia nella versione completamente in acciaio inox. Il tavolo saliscendi garantisce il massimo comfort durante l'utilizzo

*Accessoire indispensable pour les travaux de polissage; disponible dans la version classique et dans la version entièrement en acier inoxydable. L'établi qui monte et descend garantit un confort maximal lors de l'utilisation*



L 750mm  
P 520mm  
H 585mm

# Cappa aspirante Un must per il tuo laboratorio

*Hotte Un must pour votre laboratoire*

Da sempre il nostro fiore all'occhiello. La solidità è una garanzia del suo funzionamento a lunga durata. Studiata nei minimi dettagli. Disponibile in numerose versioni

*Toujours notre produit phare. La solidité est un garantie de son fonctionnement durable. Étudié dans les plus petits détails. Disponible dans de nombreuses versions*

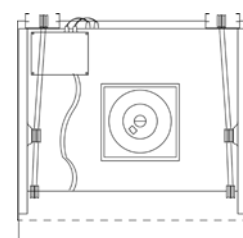

Cappa aspirante

L 810mm  
P 800mm  
H 2110mm

pg | 65-66

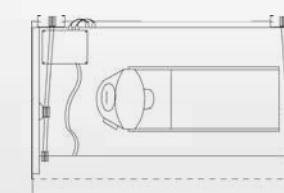

linea classica

L 1210mm  
P 800mm  
H 2110mm

IRIDE.



## Aspirazione Singola o doppia *Aspiration Pour 1 place ou 2 places*

Potente, silenziosa, dotata di motore ad induzione. Studiata per adattarsi a tutte le nostre linee da laboratorio  
*Puissant, silencieux, équipé d'un moteur à induction. Conçu pour s'adapter à toutes nos lignes des établis*



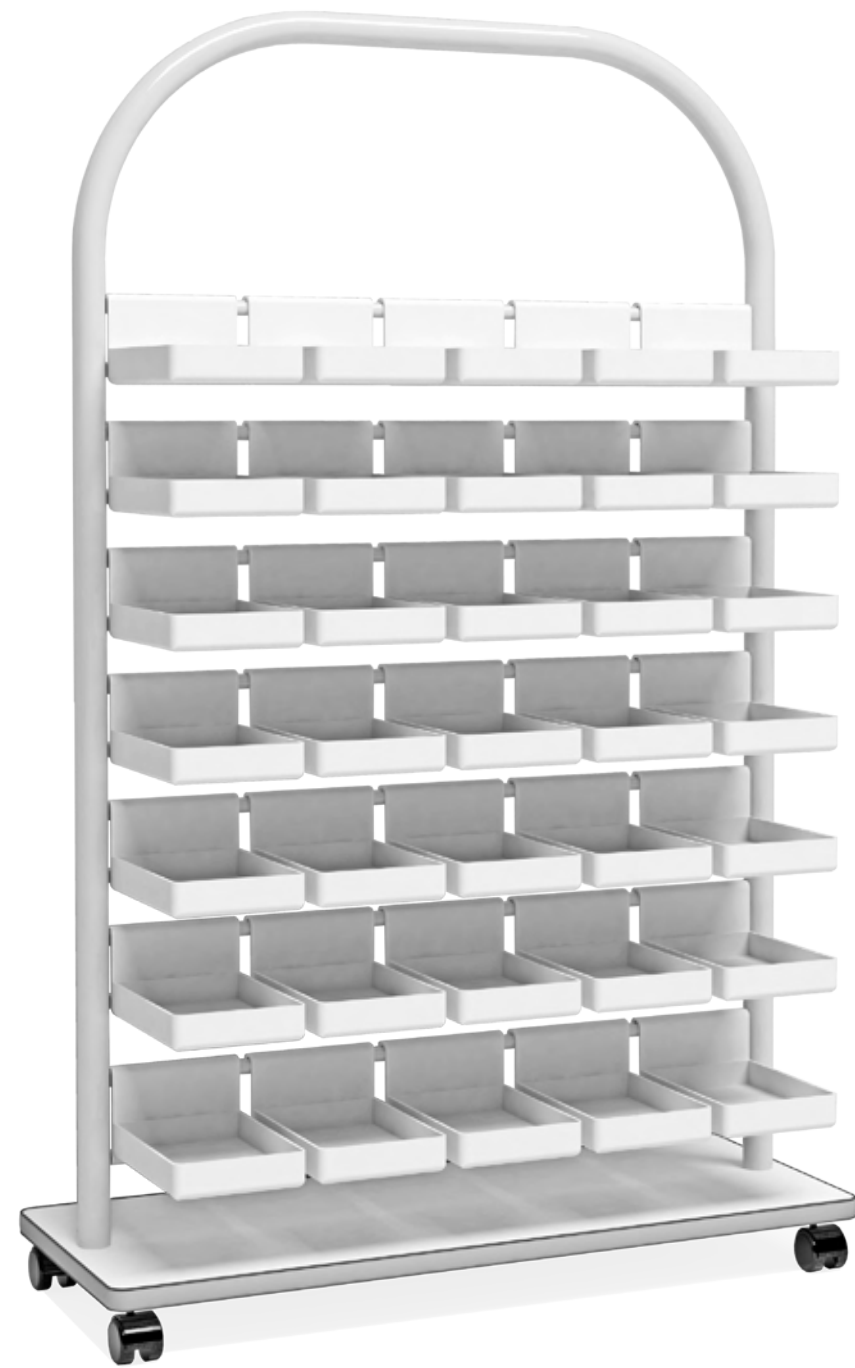

L1040mm  
P400mm  
H1700mm

Rastrelliera

pg | 69-70

# RASTRELLIERA

*Rail porte boîte*

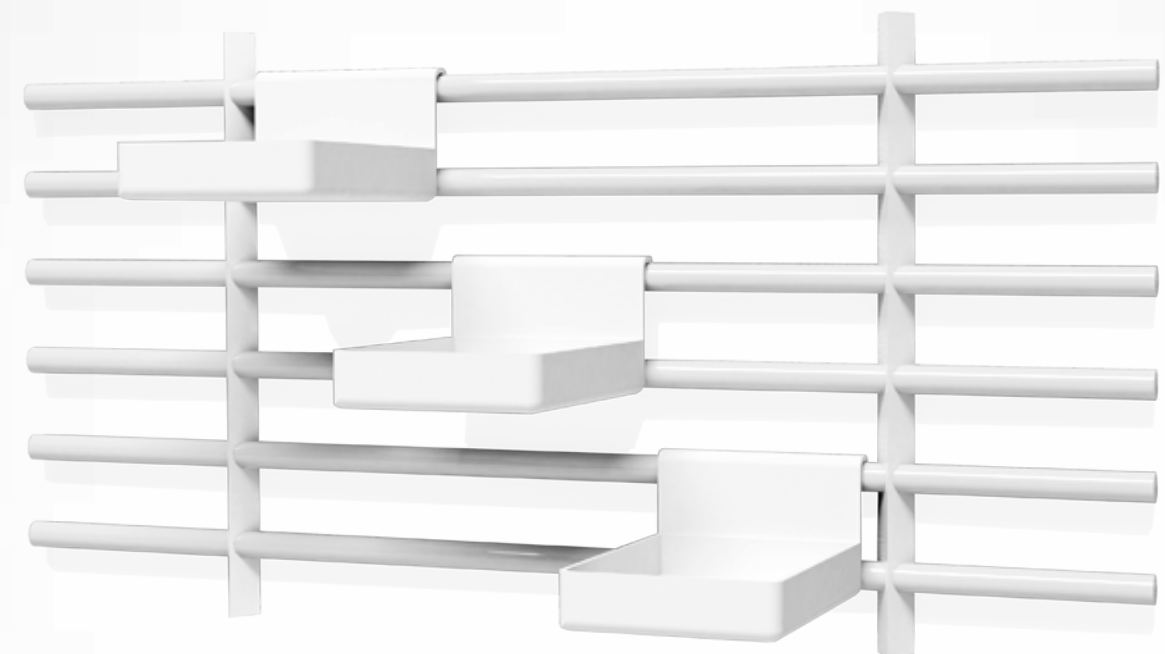

L1000/1500mm  
H500mm

linea classica

IRIDE.

**SEDIE**  
*Chaises*



Basamento in alluminio  
*Base en aluminium*



Basamento nero  
*Base noire*

**ACCESSORI PER POSTAZIONE LAVORO**  
*Accessoires place travail*

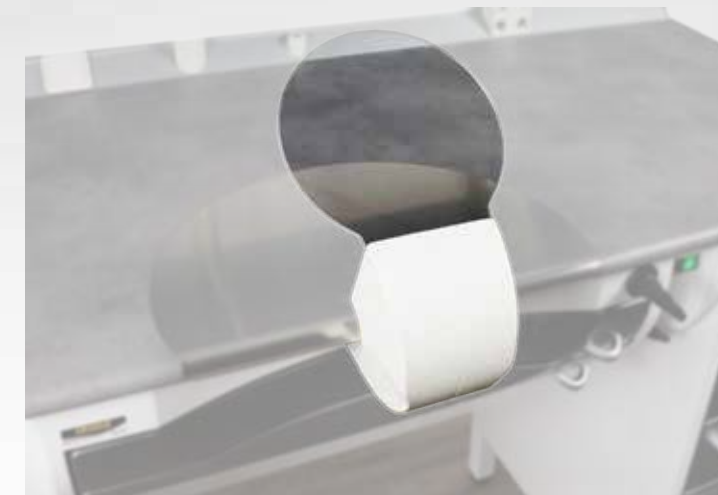

Conchiglia  
*Conchiglia*



Vetro regolabile per zeppa  
*Vitre réglable pour cheville*

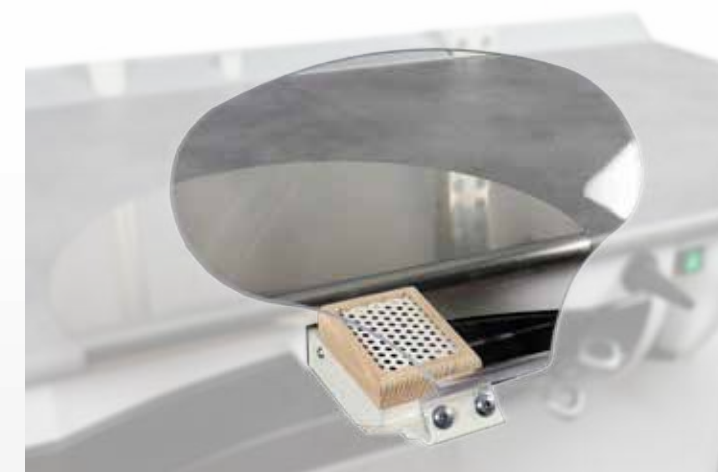

Nuvola  
*Nuvola*

# CUPOLA CON LUCE E SENZA LUCE

*Coupoles avec et sans lumière*

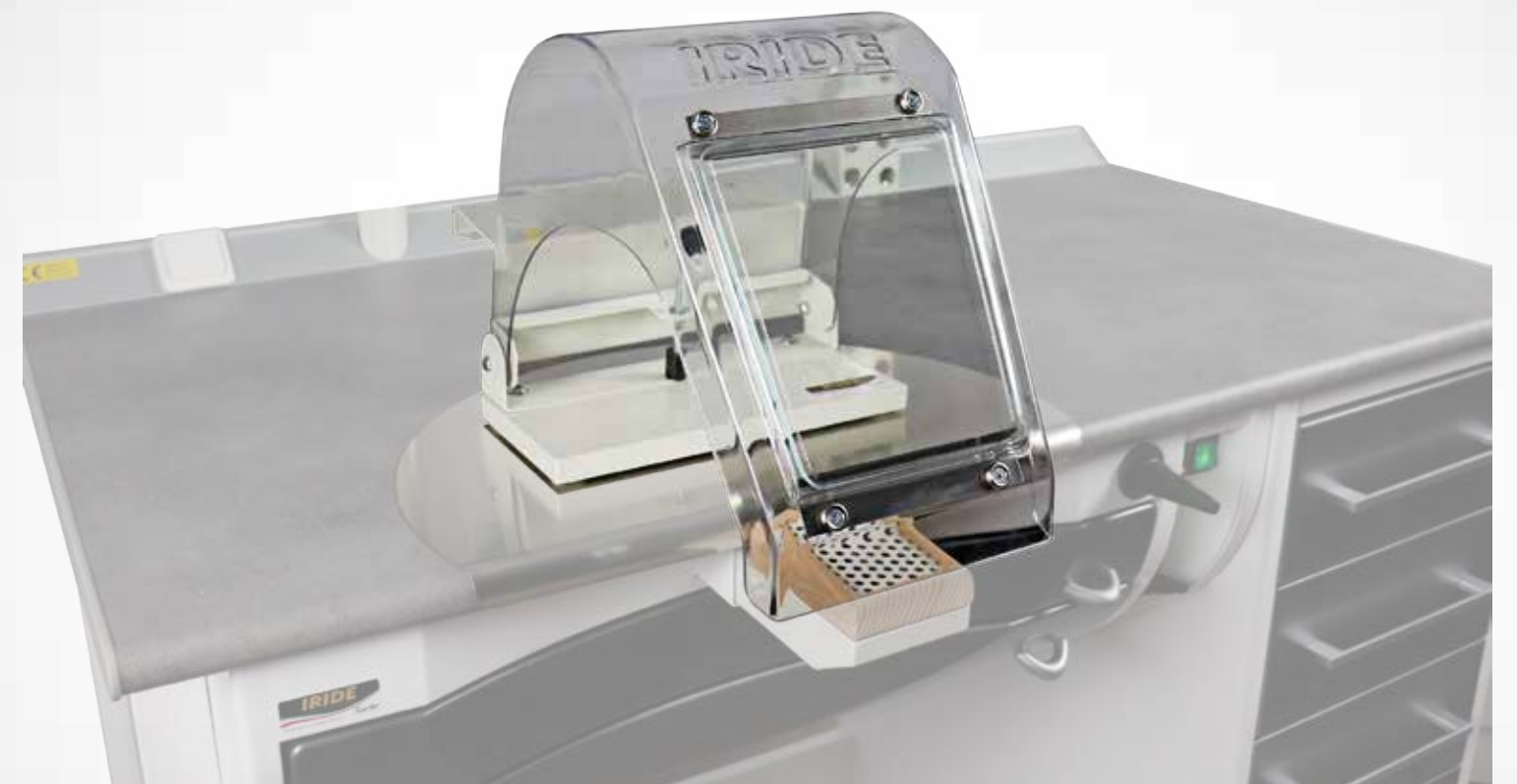

## Lampada saliscendi *Lampe mobile*

La nostra classica lampada saliscendi è provvista di un braccio che include tre punti di snodo; questo permette una totale libertà di movimento in tutte le direzioni. Disponibile in versione neon o led (dimmerabile)

*Notre lampe mobile est équipée d'un bras articulé à trois points; cela permet une totale liberté de mouvement dans toutes les directions. Disponible en version néon ou led (lumière gradable)*

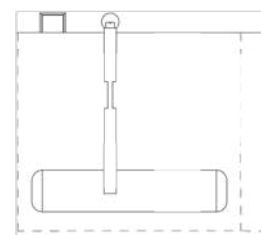

## Lampada fissa *Lampe fixe*

La nostra lampada fissa ha una peculiarità: uno snodo all'estremità del braccio permette una parziale regolazione in altezza. Disponibile in versione neon o led (dimmerabile)

*Notre lampe fixe a une particularité: une articulation en bout de bras permet un réglage partiel en hauteur. Disponible en version néon ou led (lumière gradable)*

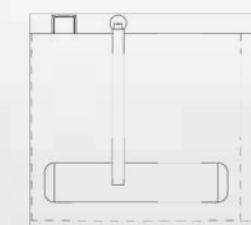

# Lampada Fly

## Lampe Fly

Una luce unica. Fly è l'ultima evoluzione dell'illuminazione; un design innovativo curato in ogni dettaglio.  
Offre infinite possibilità di regolazione di movimento e intensità di luce LED

*Une lumière led unique. Fly est la dernière évolution de l'éclairage ; un design innovant, avec une attention à chaque détail.  
Il offre des possibilités infinies de réglage du mouvement et de l'intensité de la lumière LED*

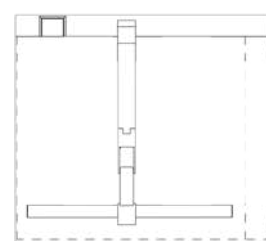

# Lampada basic

## Lampe basic

Illuminazione LED adatta a chi è alla ricerca dell'essenziale, ma non rinuncia alla funzionalità  
Un éclairage LED adapté à ceux qui recherchent l'essentiel, mais qui ne renoncent pas à la fonctionnalité

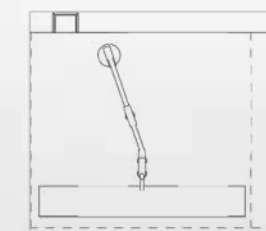
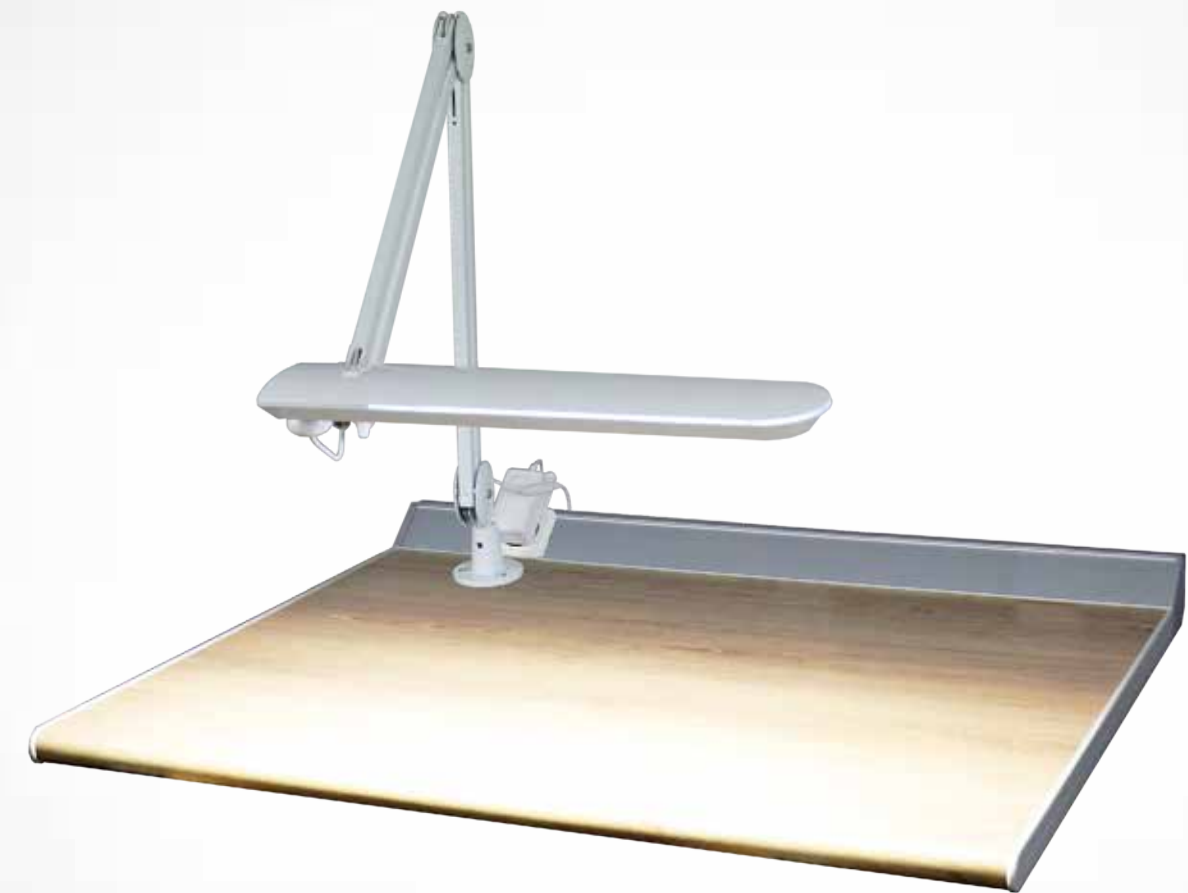



# Personalizzazioni

## Personnalisations

Colori, vetri, maniglie e materiali, scegli tra le molte opzioni disponibili e personalizza la tua composizione come hai sempre sognato!

*Couleurs, verres, poignées et matières, choisissez parmi les nombreuses options disponibles et personnalisez votre composition comme vous en avez toujours rêvé!*

### colori RAL classic /RAL couleurs classiques

1001	1006	1007	1011	1013	1014
1015	1016	1017	1018	1020	1021
1034	2000	2004	2012	3000	3002
3003	3004	3014	3015	3016	3018
3022	4001	4003	4004	4005	4007
4008	4009	5000	5001	5002	5003
5010	5011	5012	5013	5014	5018
5020	5021	5022	5024	6000	6003
6004	6018	6019	6021	6027	6029
6033	6034	7001	7002	7011	7012
7016	7030	7032	7035	7037	7038
7042	8017	9001	9002	9003	9005
9010	9016	9017	9022		

### colori speciali /couleurs spéciales

BIANCO IRIDE	NERO OPACO	VERDE MELA	VERDE POLINESIA	VERDE MADAGASCAR	AZZURRO INDIANO
GIALLIO FLUO	ARANCIO FLUO	FUCSIA FLUO	GLICINE		

### materiali/matériaux

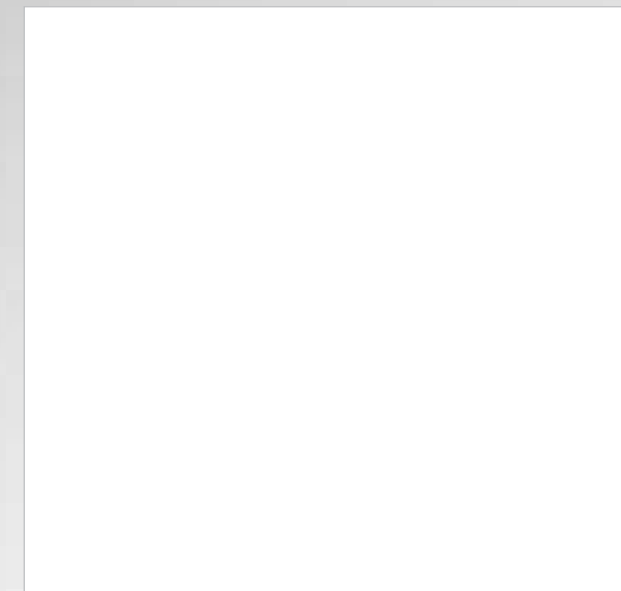

bianco

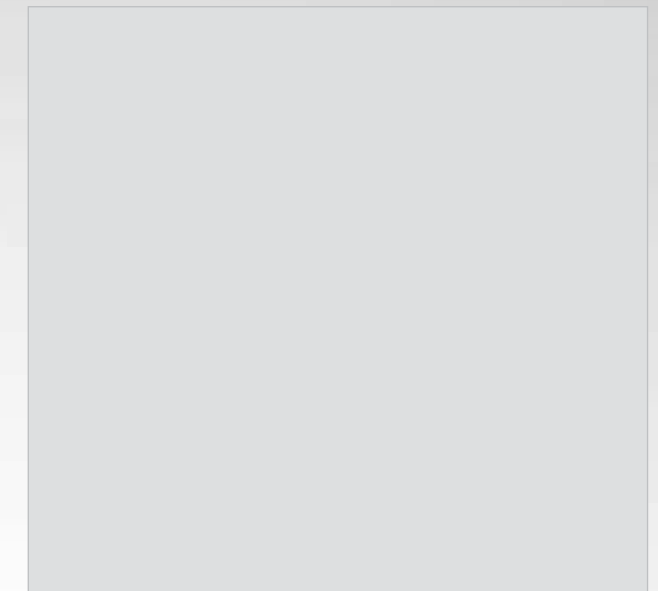

grigio chiaro



rovere chene

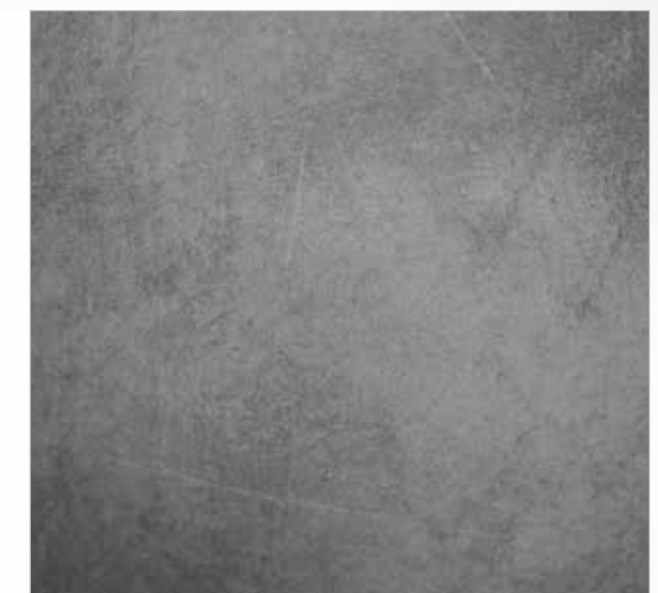

copperfield

### maniglie/poignées



luna



sheila



prince

Nel catalogo le tonalità di colore dei prodotti potrebbero risultare leggermente diverse dall'originale. I riferimenti RAL associati ai mobili sono quindi da considerarsi indicativi.

*Dans le catalogue, les nuances de couleurs des produits peuvent être légèrement différentes de l'original. Les références RAL associées au mobilier sont donc à considérer à titre indicatif.*

BANCHI

P 650 H filo piano 905 H filo alzatina 945  
 P 650 H jusqu'au plan de travail 905 H jusqu'au rail 945



BLM  
L. 660



BLM 1  
L. 730



BLM 1 -CM 2  
L.1230



BLM 101  
L. 1230



BLM 101 -35  
L. 1080

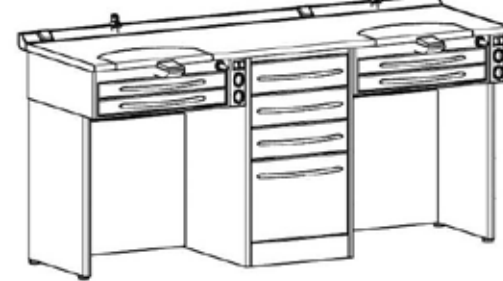

BLM 201  
L. 1940



BLM 201 -35  
L. 1790



BLM 301  
L. 2440

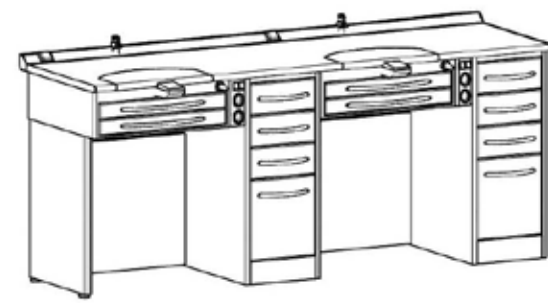

BLM 301 -35  
L. 2140

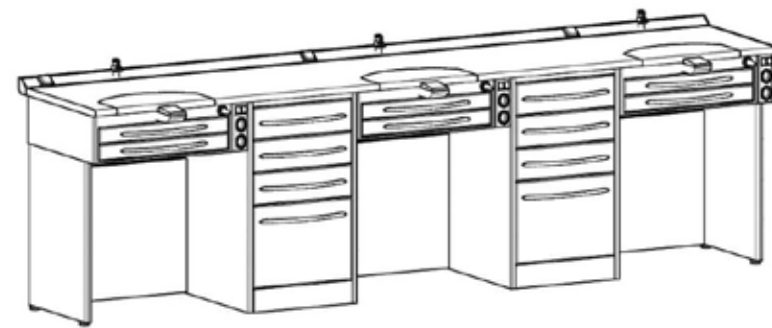

BLM 303  
L. 3150

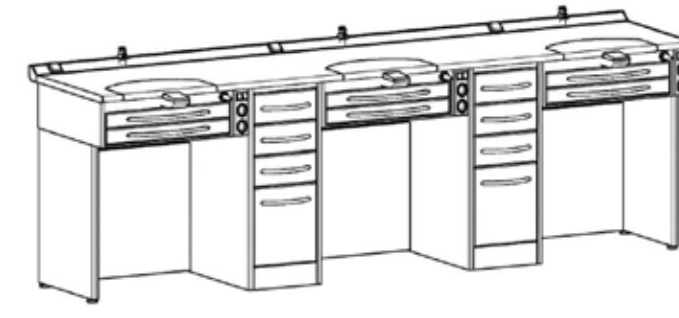

BLM 303 -35  
L. 2850

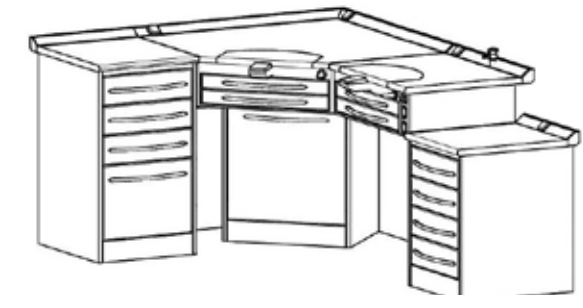

BLM -CER  
L. 1590/2300

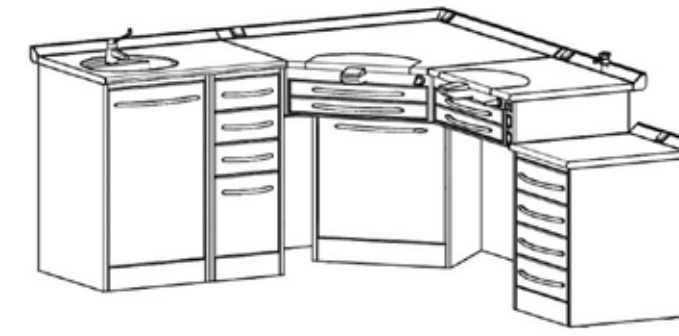

BLM -CER 1  
L. 1940/2300



BLMA  
L. 1080/1080

CASSETTIERE



CM 1 -35  
L. 370

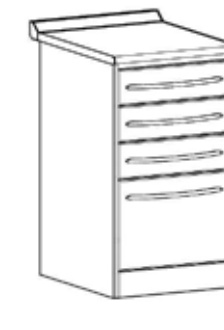

CM 1 -50  
L. 520



CM 2 -35  
L. 370 H. 700



CM 2 -50  
L. 520 H. 700



CM 3 -50  
L. 520

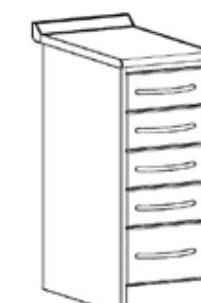

CM 8 -35  
L. 370



CM 8 -50  
L. 520



CML/C  
L. 520

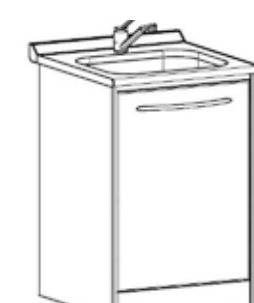

CML/G60  
L. 620

**BANCHI**

P 650 H filo piano 950 H filo alzatina 990

*P 650 H jusqu'au plan de travail 950 H jusqu'au rail 990*



TEC1D  
L. 810

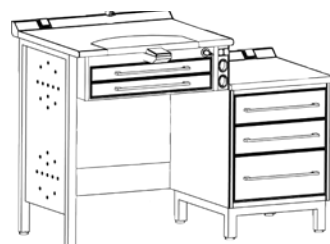

TEC1D-TM2  
L.1270

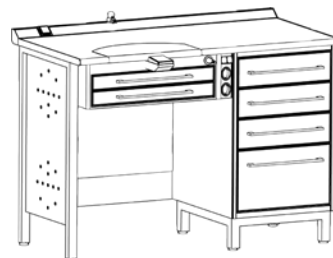

TEC101D  
L.1270

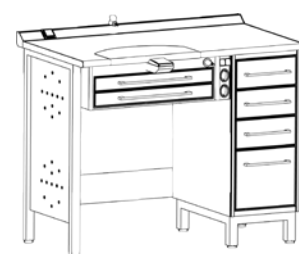

TEC101D-35  
L.1120

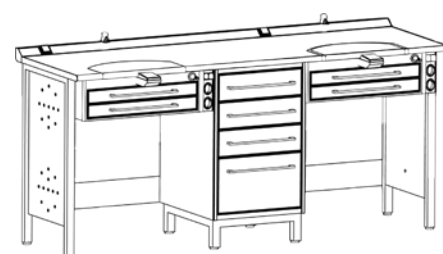

TEC201D  
L.2020



TEC201D-35  
L.1870

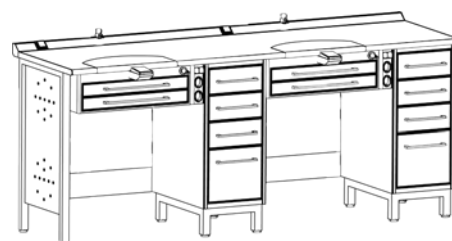

TEC301D-35  
L.2180

**CASSETTIERE**



TM1  
L.520



TM1-35  
L.370



TM2  
L.520

**BANCHI**

P 650 H filo piano 905 H filo alzatina 945  
*P 650 H jusqu'au plan de travail 905 H jusqu'au rail 945*



BLEK  
L. 660



BLEK1  
L. 750

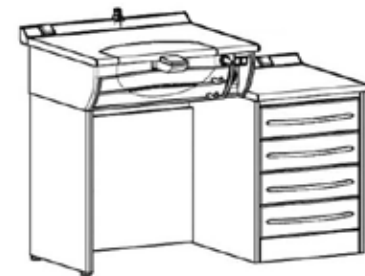

BLEK1-CM2  
L. 1250

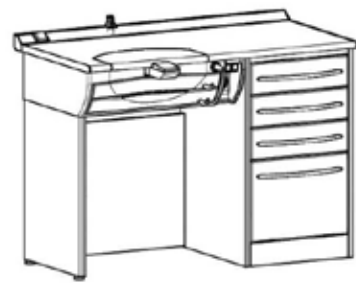

BLEK101  
L. 1250



BLEK101-35  
L. 1100

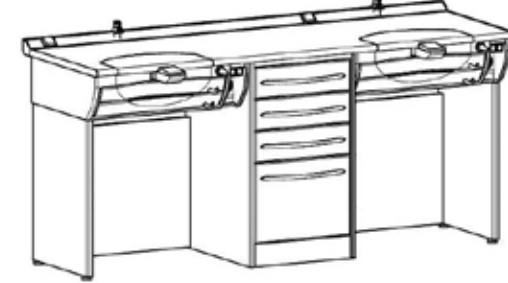

BLEK201  
L. 1980

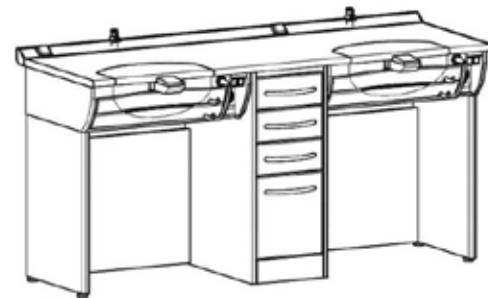

BLEK201-35  
L. 1830

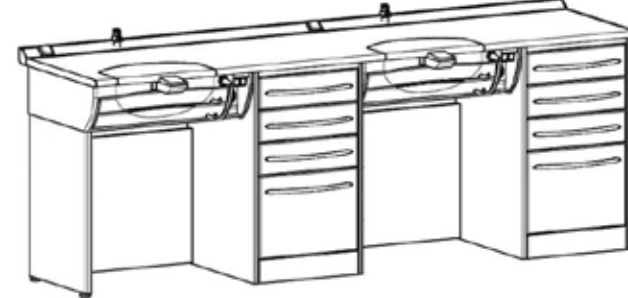

BLEK301  
L. 2480

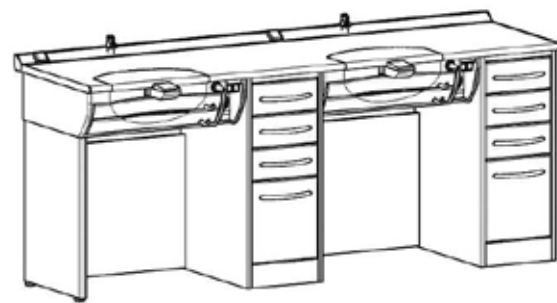

BLEK301-35  
L. 2180

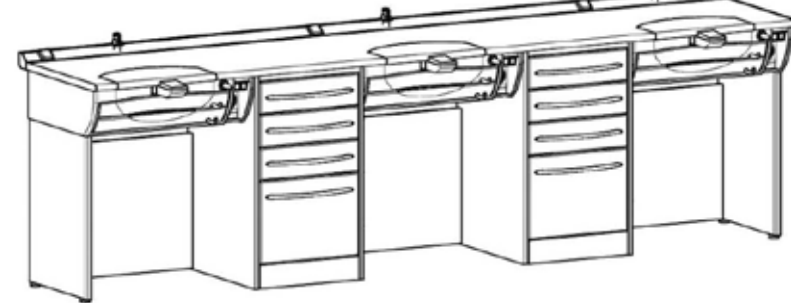

BLEK303  
L. 3210

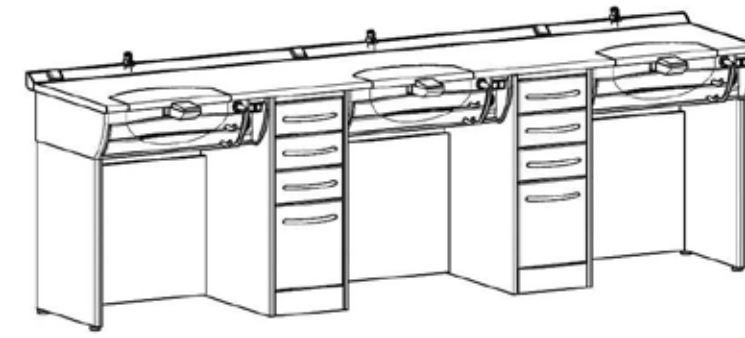

BLEK303-35  
L. 2910

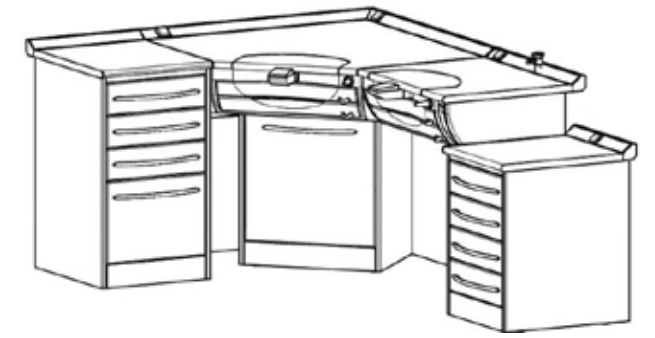

BLEK-CER  
L. 1590/2320

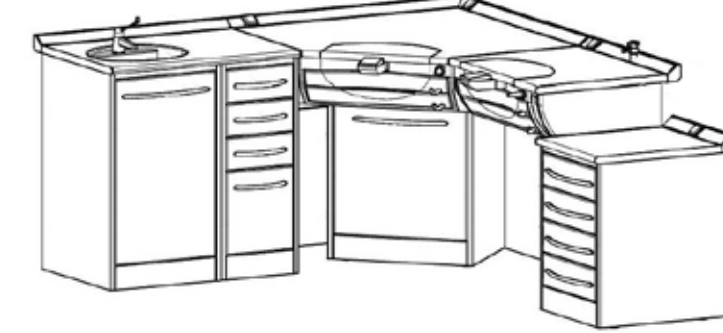

BLEK-CER1  
L. 1940/2320



BLEKMA  
L. 1080/1080

**CASSETTIERE**



CM1-35  
L. 370

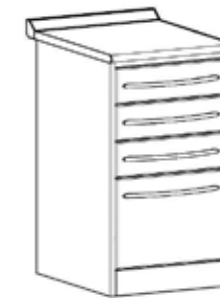

CM1-50  
L. 520



CM2-35  
L. 370 H. 700



CM2-50  
L. 520 H. 700

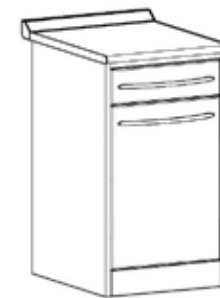

CM3-50  
L. 520



CM8-35  
L. 370

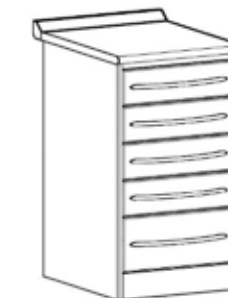

CM8-50  
L. 520



CML/C  
L. 520

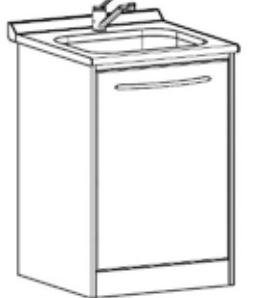

CML/G60  
L. 620

## BANCHI

P 650 H filo piano 950 H filo alzatina 990  
P 650 H jusqu'au plan de travail 950 H jusqu'au rail 990



SKY1D  
L.830

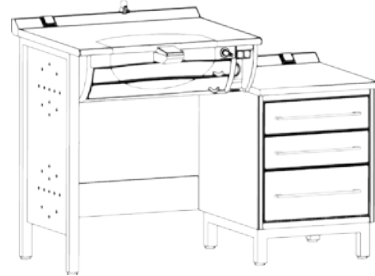

SKY1D-TM2  
L.1290

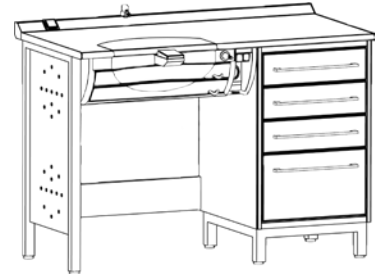

SKY101D  
L.1290

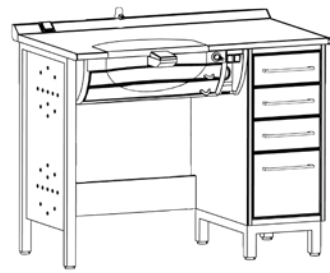

SKY101D-35  
L.1140

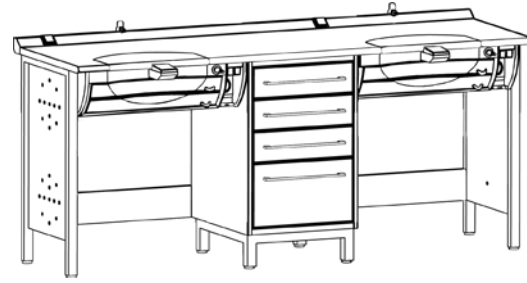

SKY201D  
L.2060

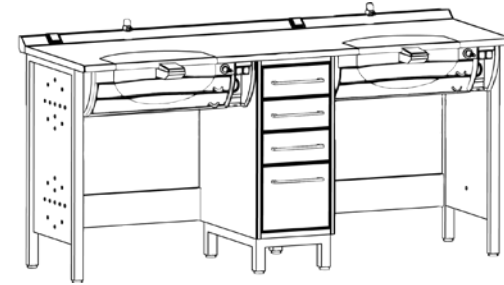

SKY201D-35  
L.1910

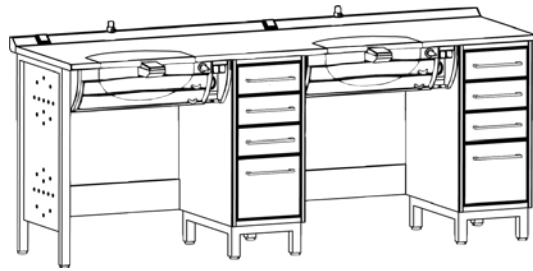

SKY301D-35  
L.2220

## CASSETTIERE



TM1  
L.520



TM1-35  
L.370



TM2  
L.520

## BANCHI

P 650 H filo piano 905 H filo alzatina 945  
 P 650 H jusqu'au plan de travail 905 H jusqu'au rail 945



BLS1  
L. 1010



BLS1/PS  
L. 1010



BLS1-CM2  
L. 1510



BLS1/PS-CM2  
L. 1510

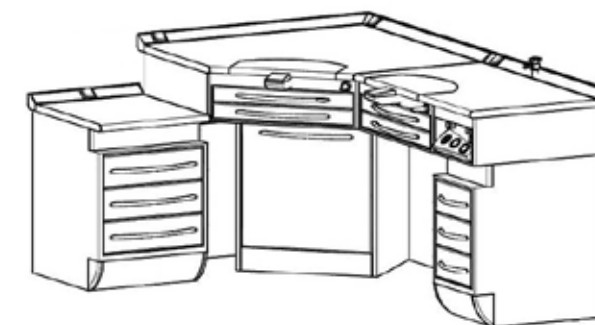

BLS-CER  
L. 1590/2080

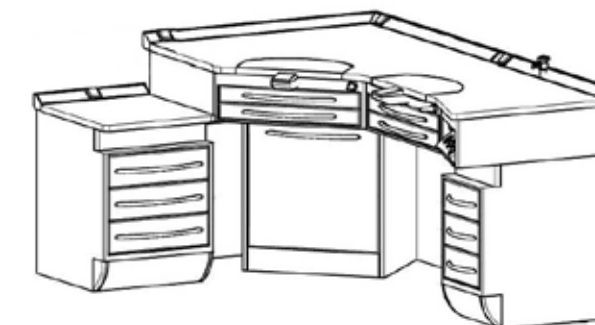

BLS-CER/PS  
L. 1590/2080



BLS135  
L. 1010



BLS135/PS  
L. 1010



BLS135-CM2  
L. 1510



BLS-CER1  
L. 2090/2080



BLS-CER1/PS  
L. 2090/2080



BLS135/PS-CM2  
L. 1510

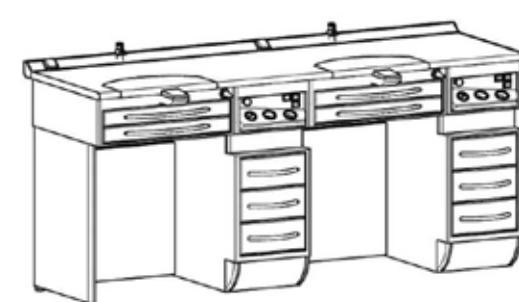

BLS235  
L. 2000

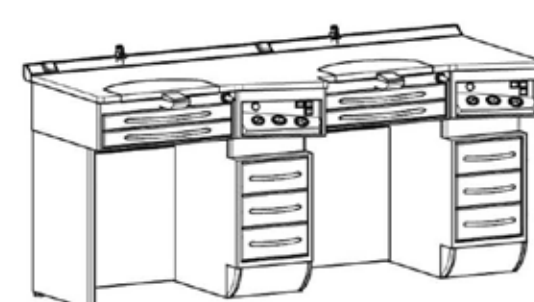

BLS235/PS  
L. 2000



BLMA  
L. 1080/1080

## CASSETTIERE

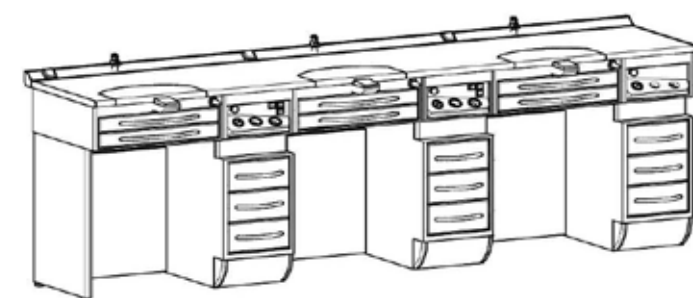

BLS335  
L. 2990

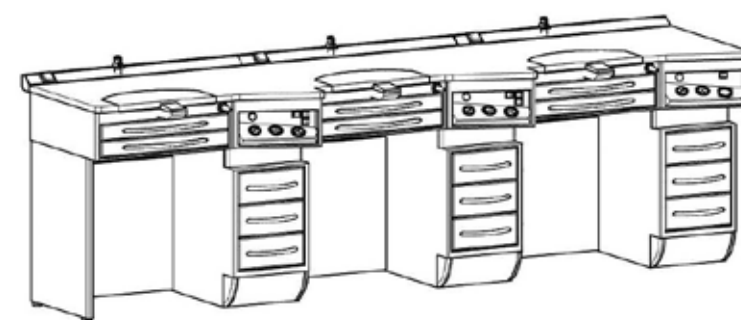

BLS335/PS  
L. 2990

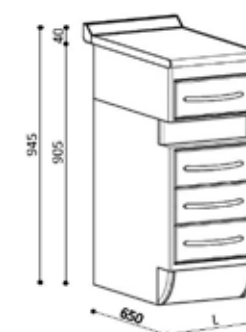

CM4/AM35  
L.370

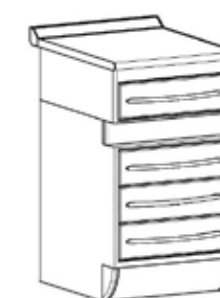

CM4/AM50  
L.520



CM5/AM35  
L.370

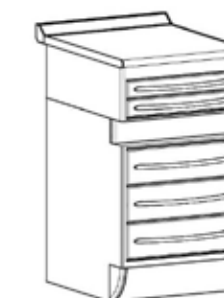

CM5/AM50  
L.520



CM2/ET35  
L.370 H.700



CM2/ET50  
L.520 H.700



CML/AMC  
L.520

## BANCHI

P 650 H filo piano 905 H filo alzatina 945  
*P 650 H jusqu'au plan de travail 905 H jusqu'au rail 945*

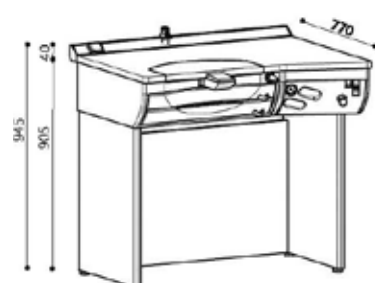

BLET1  
L.1010



BLET135  
L.1010



BLET135-CM2  
L.1510

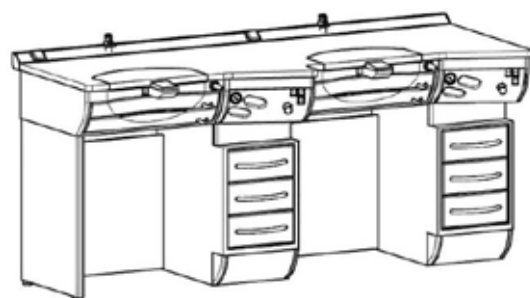

BLET235  
L.2000

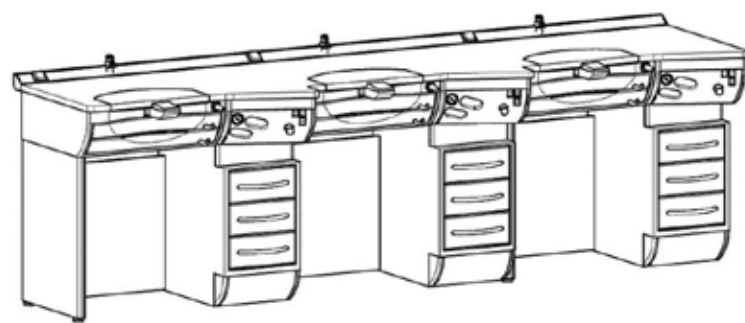

BLET335  
L.2990

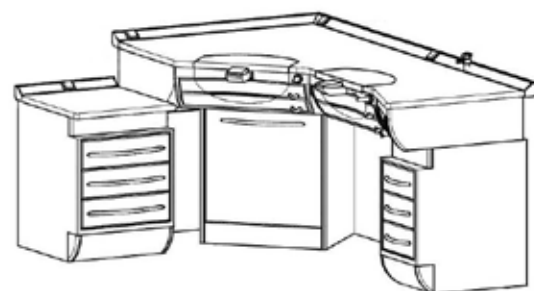

BLET-CER  
L.1590/2080

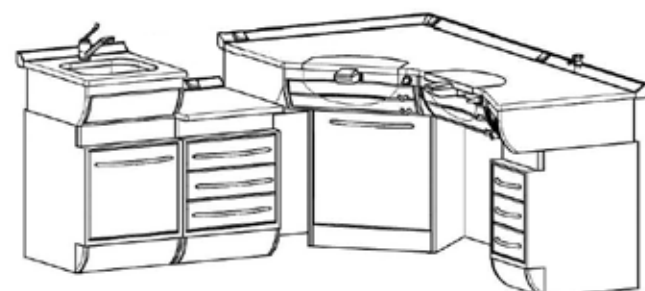

BLET-CER1  
L.2090/2080



BLEKMA  
L.1080/1080

## CASSETTIERE

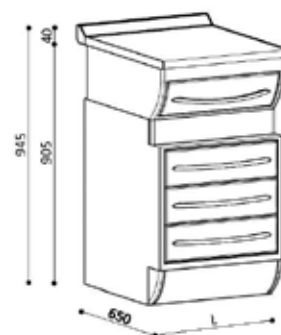

CM4/ET50  
L.520



CM1/ETC  
L.520



CM2/ET35  
L.370 H.700



CM2/ET50  
L.520 H.700

## MOBILI DI SERVIZIO

P 650 H filo piano 905 H filo alzatina 945  
 P 650 H jusqu'au plan de travail 905 H jusqu'au rail 945

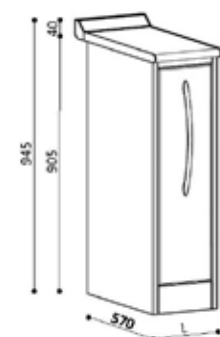

MS1-25/900  
L.270



MS1-35/900  
L.370



MS1-40/900  
L.420

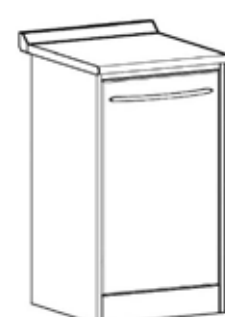

MS1/900  
L.520

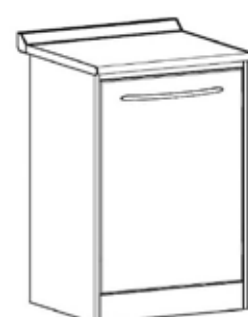

MS1-60/900  
L.620



MDS/900  
L.520



MDSG/900  
L.620



MDS1 DX/900  
L.1020



MDS1 SX/900  
L.1020

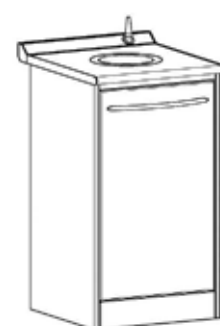

MS1G/900  
L.520



MS2/900  
L.520



MS3G/900  
L.520

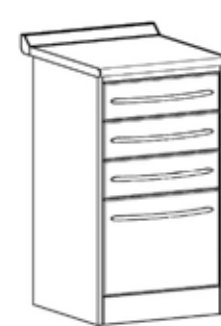

MS4/900  
L.520

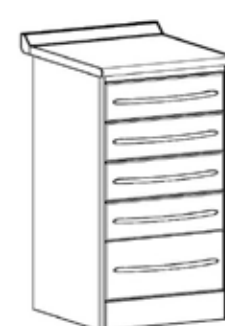

MS5/900  
L.520



MDS2/900  
L.1020



MTS1/900  
L.1520

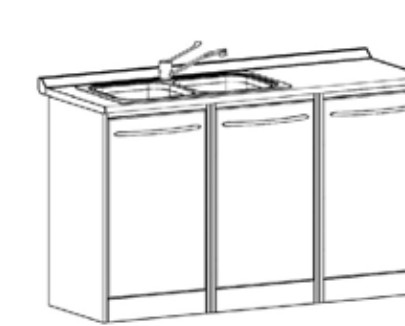

MTS2/900  
L.1520

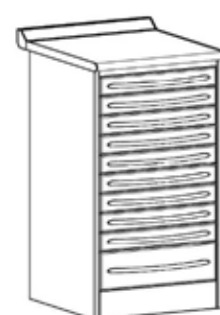

MS10/900  
L.520



MD2/900  
L.1020



MD4/900  
L.1020



MD4G/900  
L.1020

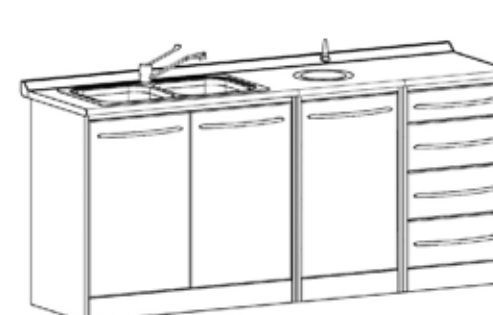

MTS2-3G/900  
L.2020



MTS2-3G/1000  
L.2020 H.1000

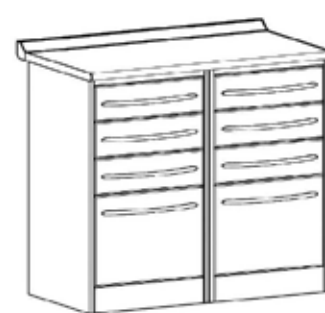

MD8/900  
L.1020

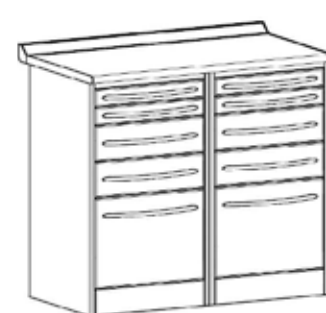

MD10/900  
L.1020



MT6/900  
L.1520



MT8/900  
L.1520

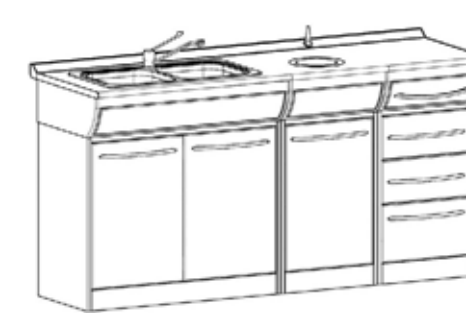

MTS2-3G/1050  
L.2020 H.1035



MLA-I/900  
L.840/840



MLA-IG/900  
L.840/840



MA/900  
L.840/840



## MOBILI DI SERVIZIO

P 650 H filo piano 950 H filo alzatina 990  
P 650 H jusq'au plan de travail 950 H jusq'au rail 990



TS1  
L.520



TS2  
L.520



TS4  
L.520



TS5  
L.520



TDS2  
L.1020

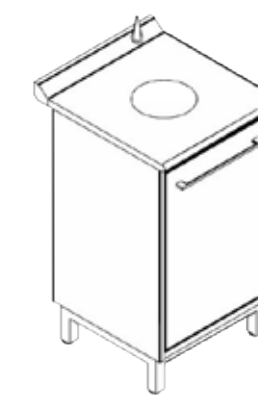

TS1G  
L.520



TD4G  
L.1020

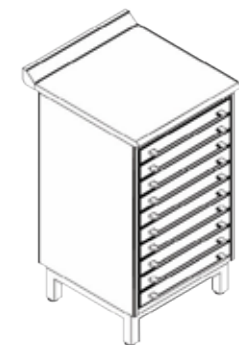

TS10  
L.520



TS3G  
L.520



TD2  
L.1020



TD4  
L.1020

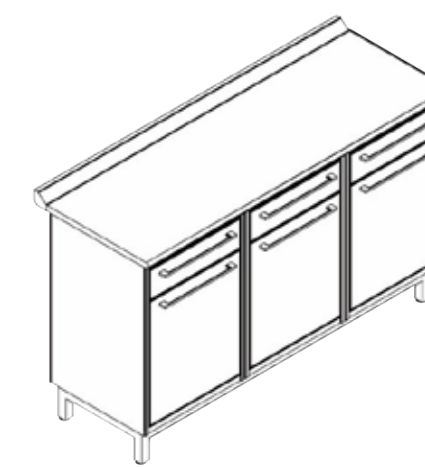

TT6  
L.1520

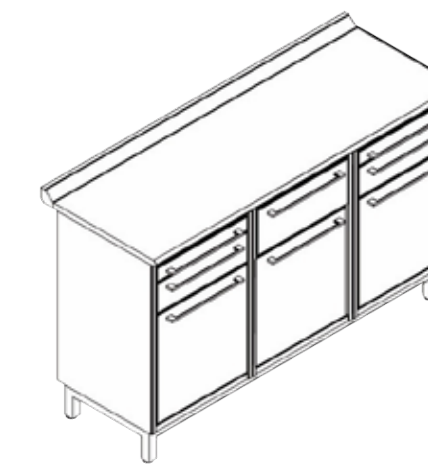

TT8  
L.1520

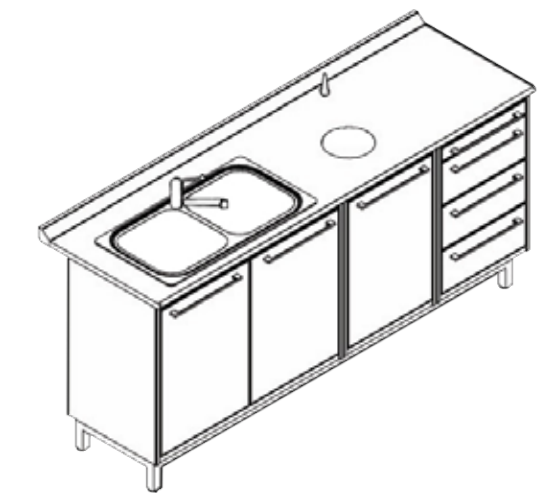

TTS23G  
L.2020



TD8  
L.1020



TD10  
L.1020



TA  
L.840

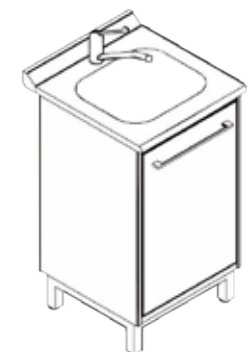

TDS  
L.520



TDS1DX  
L.1020

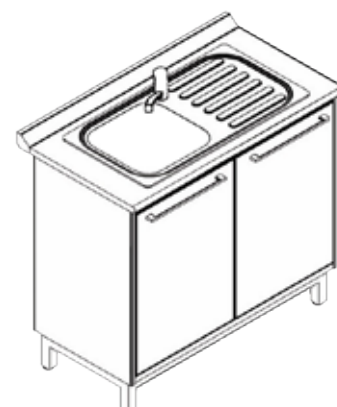

TDS1SX  
L.1020

## CAPPE

P 800 H 2110

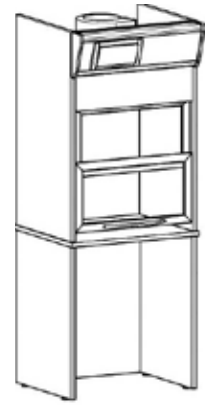

C3/R  
L.810 H.2110 P.800



C3/A1S  
L.810 H.2110 P.800



C3/C2S  
L.810 H.2110 P.800

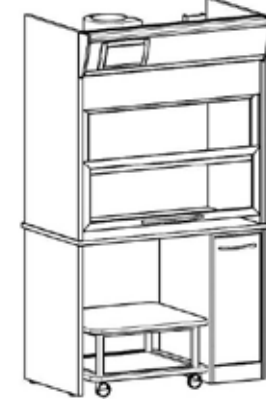

C2/RS  
L.1210 H.2110 P.800

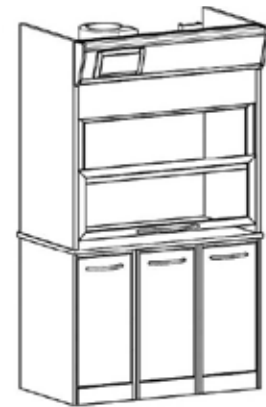

C2/A2S  
L.1210 H.2110 P.800



C2/A1C2S  
L.1210 H.2110 P.800



C2/C4S  
L.1210 H.2110 P.800

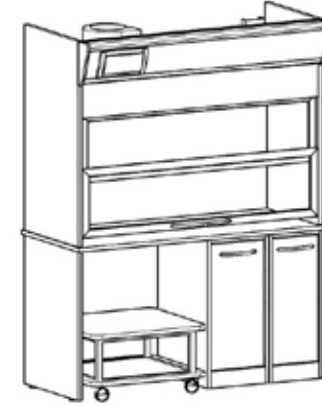

C1/RA1S  
L.1610 H.2110 P.800

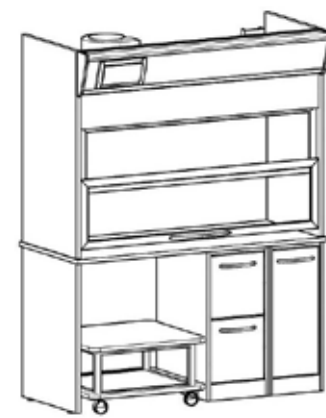

C1/RC2S  
L.1610 H.2110 P.800

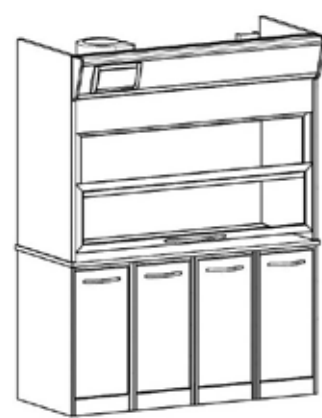

C1/A3S  
L.1610 H.2110 P.800

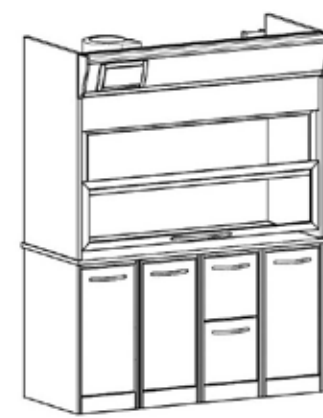

C1/A2C2S  
L.1610 H.2110 P.800

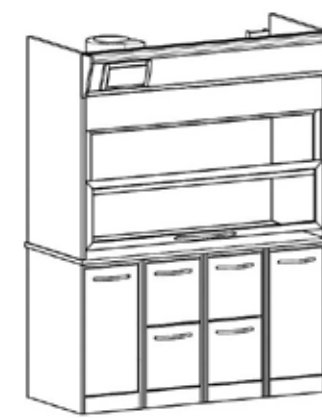

C1/A1C4S  
L.1610 H.2110 P.800



C1/C6S  
L.1610 H.2110 P.800



C3PX  
L.800 H.500 P.800



C2PX  
L.1200 H.500 P.800



C1PX  
L.1600 H.500 P.800

## BOX CERAMICA

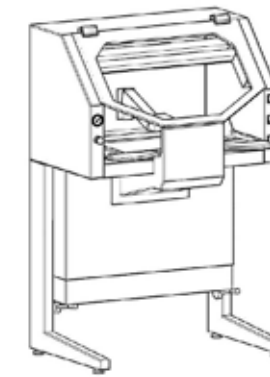

BOX CERAMICA  
L.840 H.1330 P.670

## MINI BOX

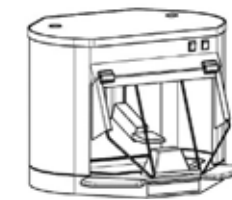

MINI BOX  
L.710 H.550 P.620



TMXC  
L.730 H.840 P.650

## CAPPETTE

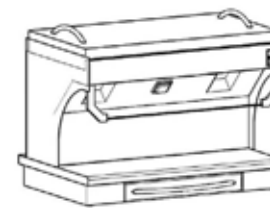

CAPPETTA  
L.750 H.585 P.520



TMXC  
L.750 H.840 P.650

IRIDE International srl  
Via San Giuseppe 5  
33082 Azzano Decimo (PN) Italy  
Tel 0434/633242 Fax 0434/632546  
[www.irideinternational.com](http://www.irideinternational.com)  
[welcome@irideinternational.com](mailto:welcome@irideinternational.com)

IRIDE.